



**The fascinating world of Tosoh Zeolites. . .  
where evolution will not stop**



- ◆ **Molecular Sieves [ZEOLUM®]**
  - Potassium A (A-3 Series)
  - Sodium A (A-4 Series)
  - Calcium A (A-5 Series)
  - Sodium X (F-9 Series)
  - Lithium LSX (NSA-700)
  
- ◆ **High Silica Zeolites [HSZ®]**
  - BETA (HSZ-900 Series)
  - ZSM-5 (HSZ-800 Series)
  - Ferrierites (HSZ-700 Series)
  - Mordenites (HSZ-600 Series)
  - L-TYPE (HSZ-500 Series)
  - Y-TYPE (HSZ-300 Series)

# Potential is only limited by one's imagination

Tosoh offers a broad line up of high-quality synthetic zeolite products. The unique and varied properties of zeolites support our society not only in industry but also in environmental fields and even in our everyday lives.

## Environment

**The selective adsorption properties of zeolites are widely utilized.**

- Detoxification of emission gases generated from semi-conductor manufacturing processes
- Adsorption and removal of volatile organic compounds emitted from printing, painting and other facilities
- Odor removal in everyday life and industry
- Adsorption (ion exchange) of radioactive materials such as Cesium or Strontium



## Chemical Manufacture

**Tosoh's technologies broaden the use of zeolites in the chemical industry.**

- Adsorbents and catalysts in oil refining
- Removal of water and impurities from naphtha cracked gas for ethylene production
- Drying agent in chlorofluorocarbon production
- Removal of water and impurities in polymerization processes
- Drying of solvents

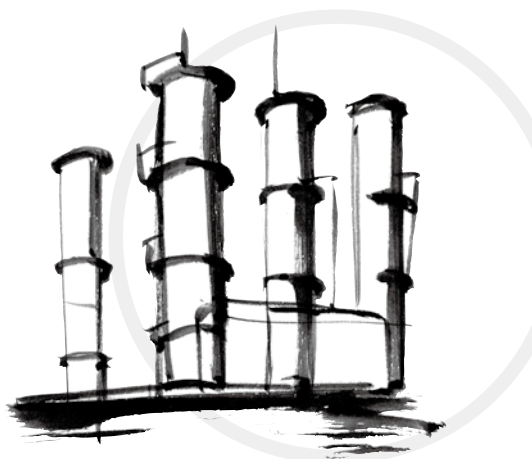

## Industrial Gases

**Zeolites are utilized for high purity gas generation.**

- Adsorption of nitrogen to allow oxygen production via PSA and VPSA processes
- Adsorption of carbon dioxide for feed prepurification in cryogenic oxygen and nitrogen plants
- Removal of sulfur from LPG gas

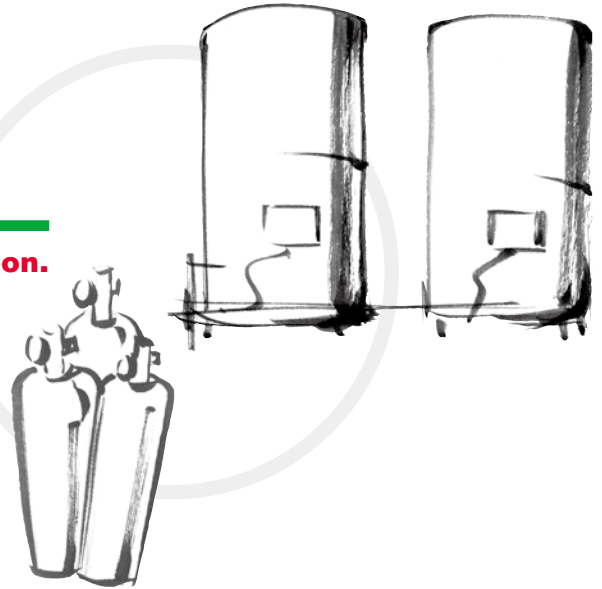

## Daily Life

**Improving the performance and usefulness of many products.**

- Prevention of cloudiness in multilayer glass by adsorbing moisture
- Drying of refrigerants and machine oil used in refrigerators, freezers and air conditioners
- Removal of water from SF6 gas used in electrical substations
- Drying of pharmaceuticals and precision instruments
- Adsorption of heat as a heat generation agent
- Removal of sulfur from fuel cell

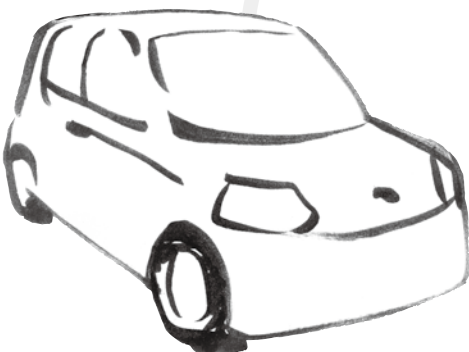
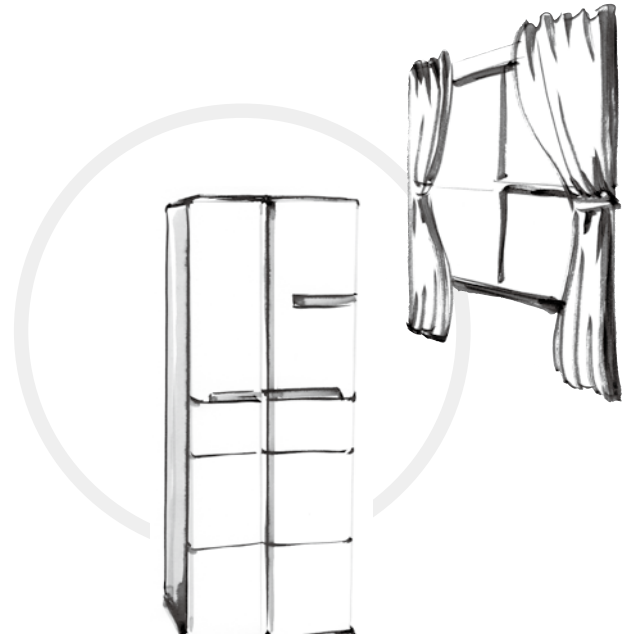

## Automobiles

**Zeolites play an important role in our automotive society.**

- Reduction of emissions by aiding in adsorption and decomposition of hydrocarbons and nitrogen oxides in exhaust gas
- Purification of bio-ethanol which is growing in importance as an alternative fuel
- Improving brake pad reliability

# Zeolite: An Extraordinary Material

Zeolite is a generic term for crystalline hydrous aluminosilicates, described by the chemical formula  $Me_2/xO \cdot Al_2O_3 \cdot mSiO_2 \cdot nH_2O$  (Me: metal ion), and has diverse structures and compositions. Zeolites were first discovered in the 18th century as a natural mineral which provides adsorption capacity. However, since the birth of synthetic zeolite, its application has been greatly expanding. Tosoh, as a diversified chemical company, offers a wide range of high-purity and high-quality zeolite products and is dedicated to R&D and customer support.

## Pore size distribution

Tosoh's zeolite, are composed of well and regularly connected silica and alumina. As such, they have a quite sharp pore size distribution, resulting in precision adsorption capacity of target materials.

### Image of pore size distribution

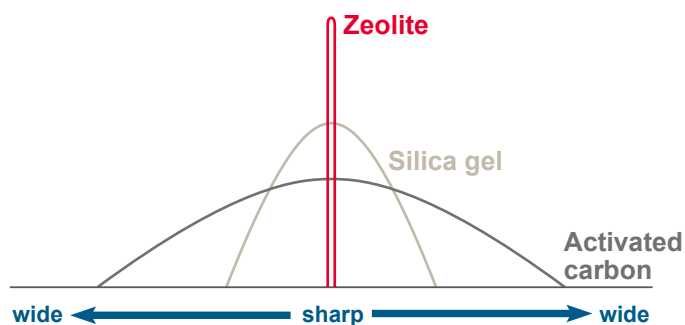

## Diversity of crystal structures

Tosoh offers various zeolite types with different crystalline structures allowing for precise adsorption of diverse target materials.

### A-TYPE

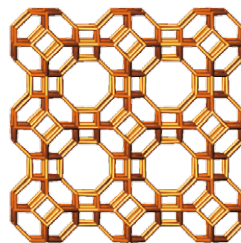

### X-TYPE

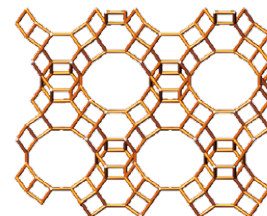

### BETA

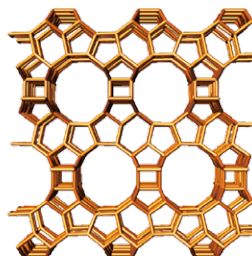

### ZSM-5

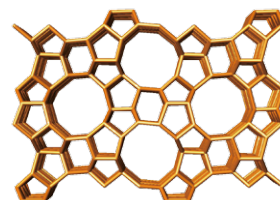

### Ferrierite

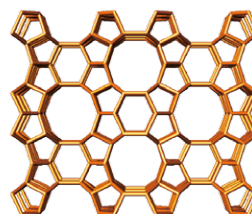

### Mordenite

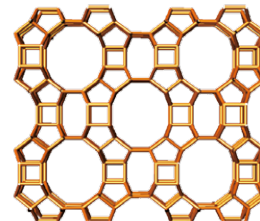

### L-TYPE

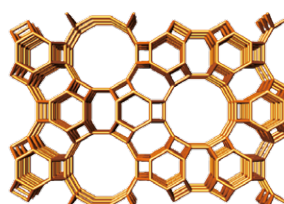

### Y-TYPE

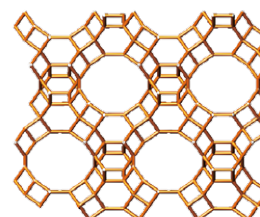

## Selective adsorption capacity control by ion exchange

Zeolites generally have cations such as potassium, sodium or calcium in their crystal structure. The pore size of Tosoh's zeolites can be modified by ion exchange, allowing them to be adjusted to meet a specific adsorption target.

### Ion position in zeolite

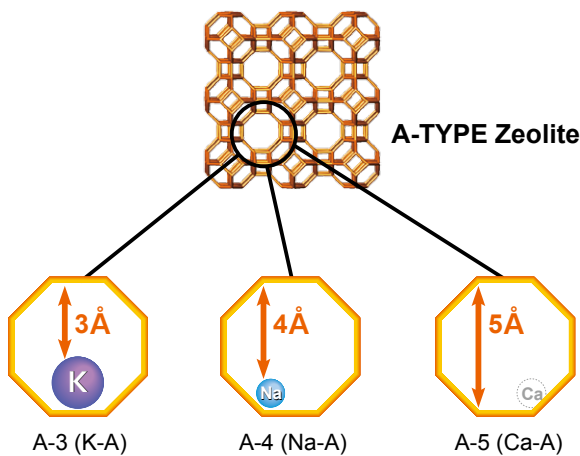

("Ca ion exists in the place which is behind the pore window")

## Safety and reliability as nonflammables

Zeolite itself is not oxidized and is nonflammable and easy to handle.

\* Example of flammables used with zeolite;  
methane, iso-butane, ethanol, hydrogen, etc.

## Specific functionality by silica/alumina ratio control

Zeolites are crystalline materials composed of silica and alumina. Their properties and function can be changed by controlling the silica:alumina ratio.

Tosoh offers various grades based on the customers specific needs such as:

- Hydrophilicity / hydrophobicity
- Thermal stability
- Catalytic properties such as acid amount and acid strength

### Hydrophilicity and thermal stability

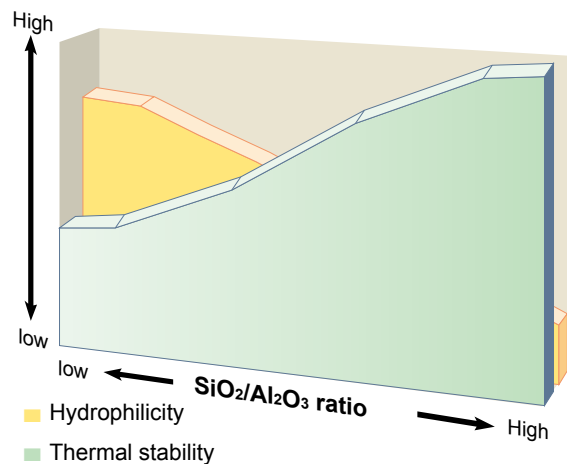

### Catalytic properties

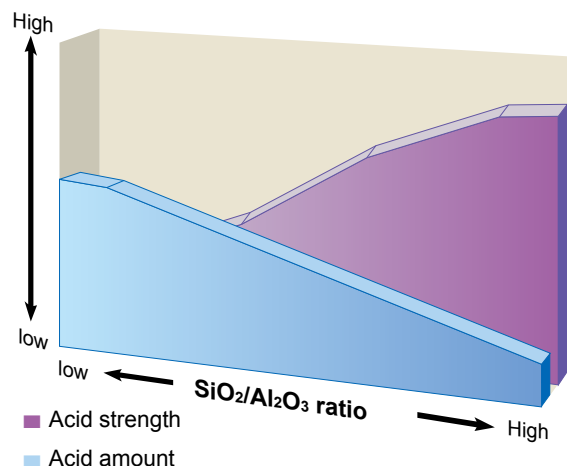



## ZEOLUM® – Tosoh's Molecular Sieves

ZEOLUM is an A-type or X-type zeolite having superior selective adsorption capacity. ZEOLUM features stronger adsorption performance than activated alumina or silica gel and is widely used for the drying and purification of various gases and liquids. ZEOLUM is especially suitable for water adsorption due to its high hydrophilicity.



Bead



Pellet



Powder

### Properties of ZEOLUM

#### Water adsorption capacity

Superior adsorption capacity even under low partial pressure fields.

Its adsorption capacity is up to 10 times larger than activated alumina or silica gel.

ZEOLUM shows high adsorption capacity even under high temperatures as compared to activated alumina or silica gel.

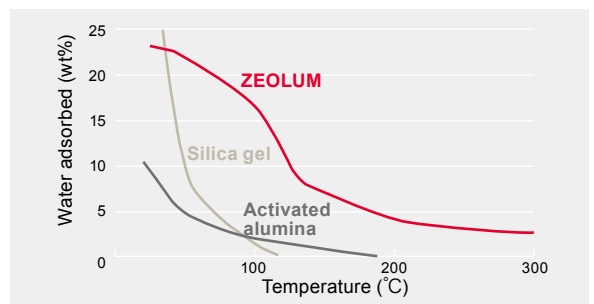
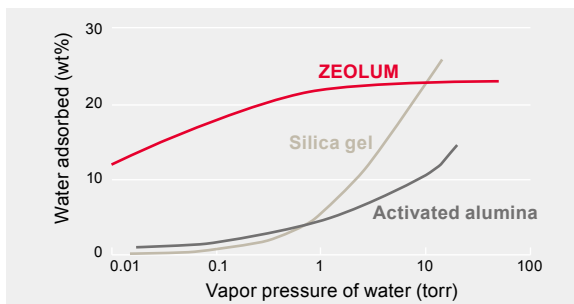

### Advantage of ZEOLUM

#### ● Binderless Grades: F-9HA, SA-500A, SA-600A, NSA-700

Binder used for molding is converted into zeolite through a proprietary treatment.

Due to this binderless treatment, adsorption capacity is improved approximately 20% as compared to conventional pelletized zeolites. Therefore the same productivity can be achieved with less quantity of zeolite.

## Li-LSX Molecular Sieve NSA-700

ZEOLUM NSA is a low-silica X-type zeolite and as such features an enhanced adsorption capacity due to its high alumina content. Moreover, its adsorption capacity for nitrogen and other particular gases are maximized by its lithium ion. ZEOLUM NSA is mainly used for O<sub>2</sub>-Vacuum Pressure Swing Adsorption.

### Properties of ZEOLUM NSA

O<sub>2</sub> productivity is greater than other conventional zeolites.

#### Adsorption isotherms of N<sub>2</sub>

N<sub>2</sub> adsorption amount is as high as SA-600A.

N<sub>2</sub> adsorption isotherms of various adsorbents(25°C)

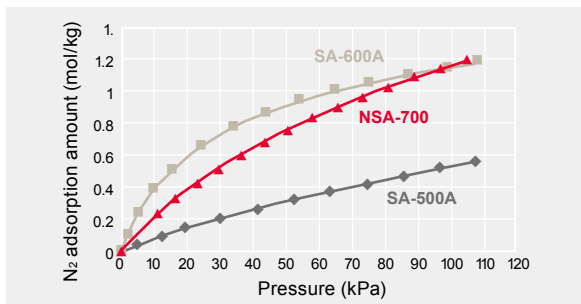

#### Adsorption isotherms of O<sub>2</sub>

O<sub>2</sub> adsorption amount is as low as SA-500A.

O<sub>2</sub> adsorption isotherms of various adsorbents(25°C)

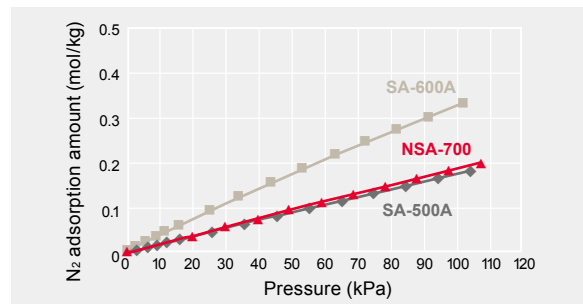

#### O<sub>2</sub> productivity comparison – relative values

O<sub>2</sub> productivity of NSA-700 is the highest due to a large difference between its N<sub>2</sub> adsorption amount and O<sub>2</sub> adsorption amount.

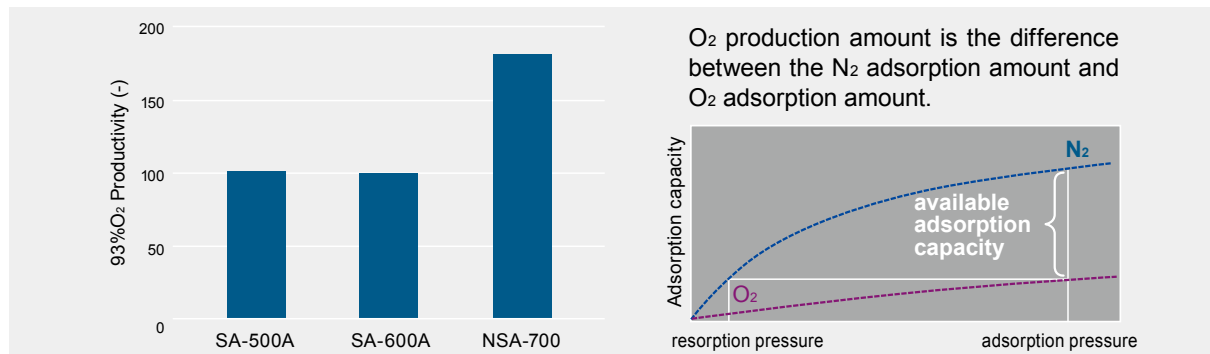

#### System image of O<sub>2</sub>-PSA

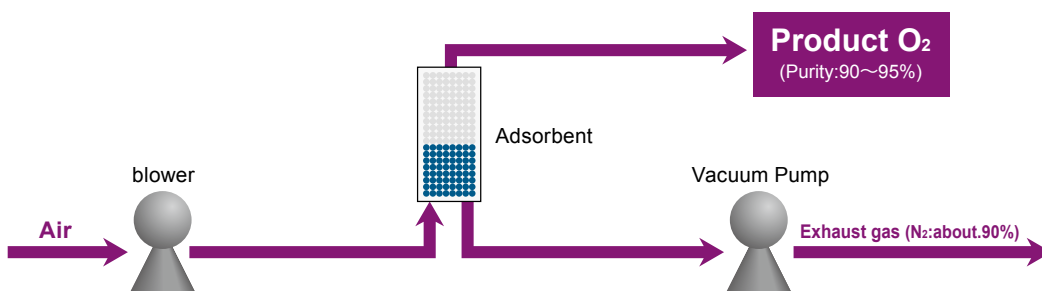



# HSZ® – High-Silica Zeolite

HSZ has an even higher silica:alumina ratio than that of ZEOLUM. Tosoh's HSZ features superior thermal and acid stability and is used as a catalyst or hydrophobic adsorbent. HSZ is widely used for automobile catalysts and VOC traps as well as in oil refinery and petrochemical industries.

We can offer not only powder but also pellet.

## Properties of HSZ

### Adsorption capacity (hydrophilicity and hydrophobicity)

Hydrophobicity of HSZ can be controlled by changing its silica/alumina ratio. Therefore, HSZ can adsorb target materials even under very moist conditions.

#### Change in adsorption capacity

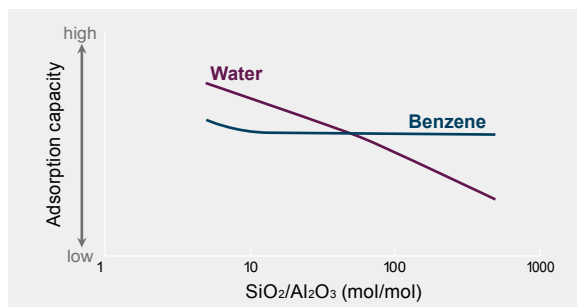

### Catalytic property (acid strength and acid amount)

In addition to its adsorption capacity, acid strength and acid amount of HSZ can be controlled resulting in optimized reactions when used as a catalyst.

#### Change in catalytic properties

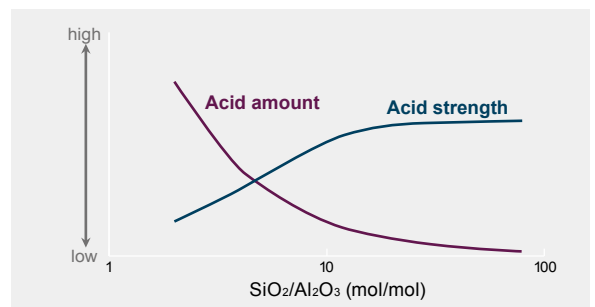

### Hydrothermal stability

Hydrothermal stability of HSZ can be improved by raising silica:alumina ratio and optimizing other zeolite properties. Therefore, HSZ remains useful even after high temperature aging under moist conditions.

#### HSZ-900 series

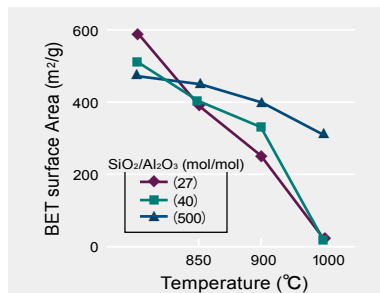

#### HSZ-800 series

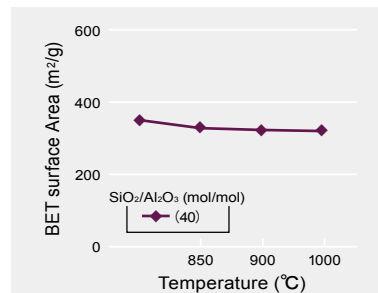

#### HSZ-700 series

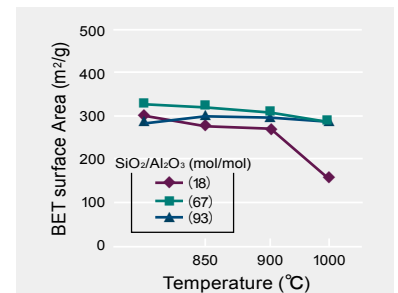

#### HSZ-600 series

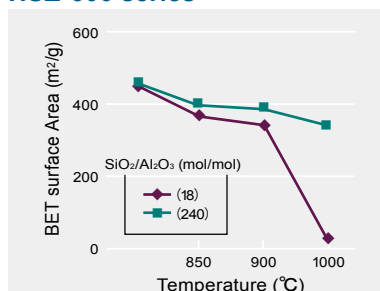

#### HSZ-300 series

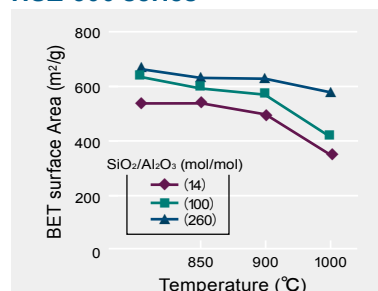

※BET surface area after aging at each temperature with air containing 10% water.



## Examples

### Use in exhausted gas control systems

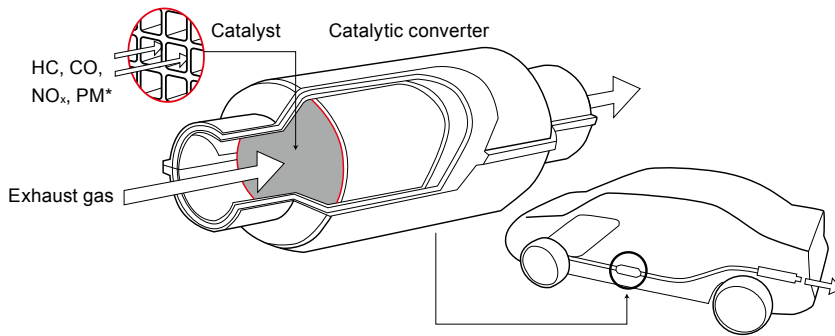

HSZ is used as a catalytic material to help control vehicle emissions in response to increasing regulations year by year. HSZ is used by coating honeycomb-shaped supports along with other catalytic materials.

### Use in oil refining and as a petrochemical catalyst

Fluid catalytic cracking (FCC)

Hydrocracking

Aromatizing lower hydrocarbons

Alkylating, isomerizing aromatic hydrocarbons

Synthesizing various chemicals

### Use in honey-comb rotor

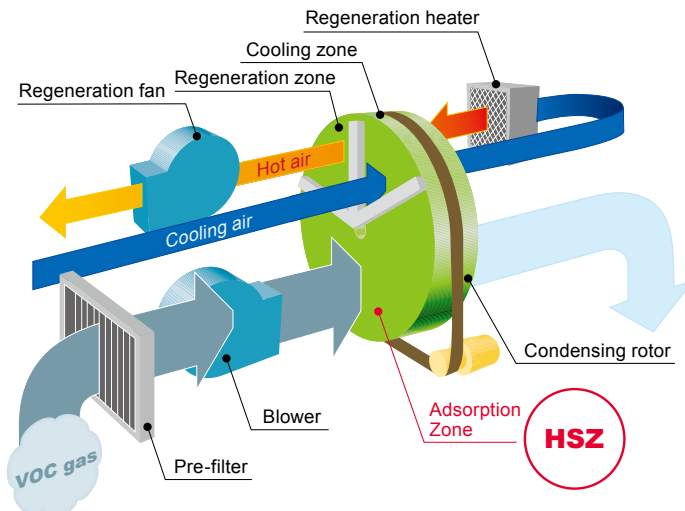

HSZ is widely used as an adsorbent for VOC's such as toluene or benzene due to its superior adsorption properties. HSZ will become more essential as regulation of VOC emissions become stricter.

# How to select grade

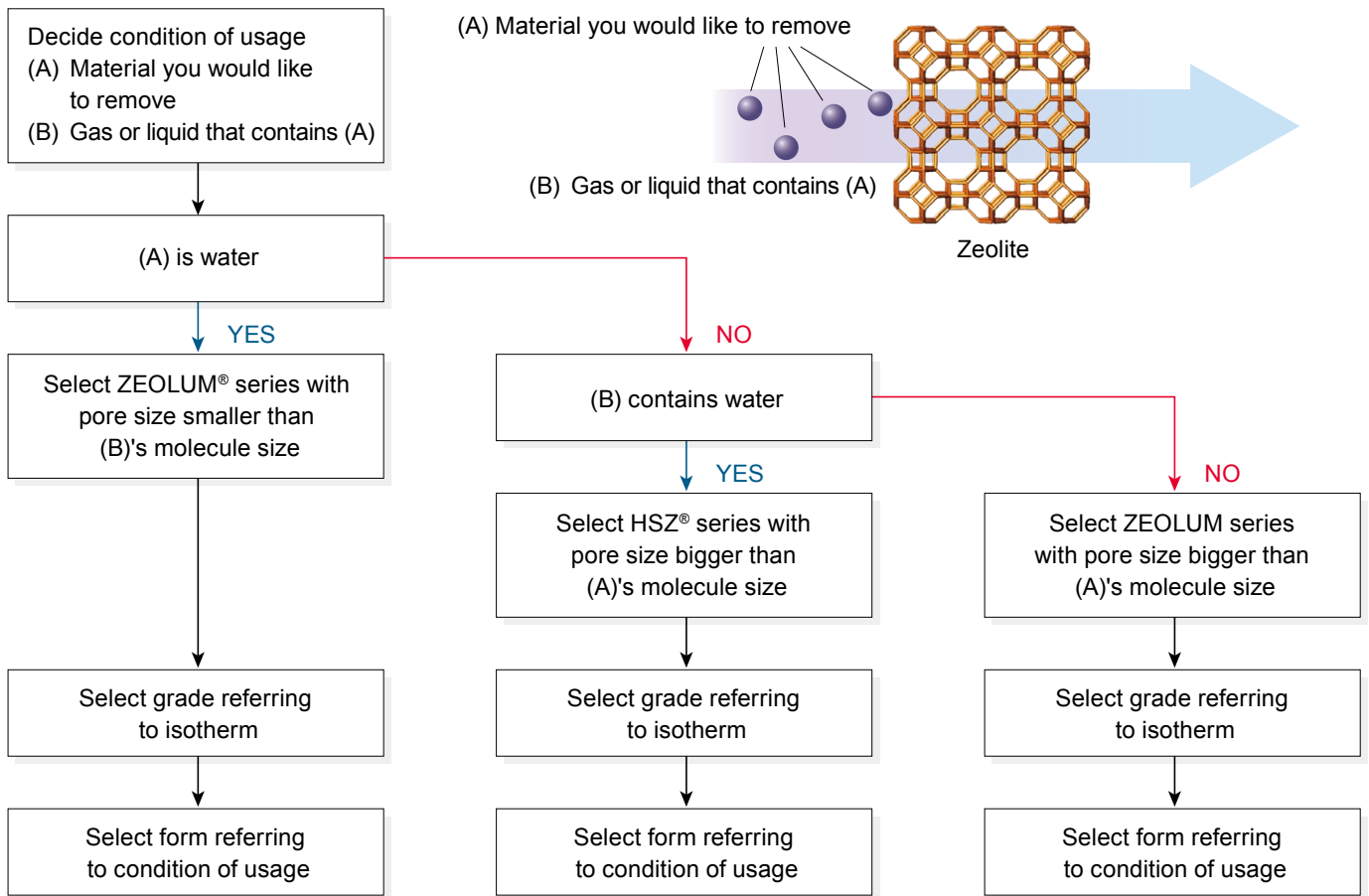

Please don't hesitate to make special requests.

## Pore size of zeolite and size of molecule

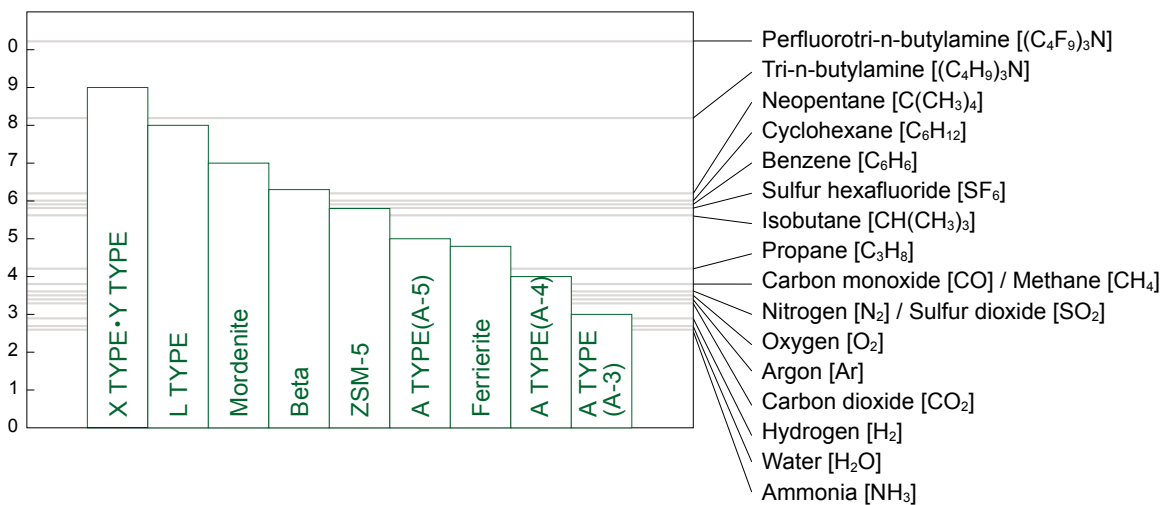

# Packaging

## ZEOLUM®, HSZ® Pellet Series

200L drum



40L drum

Sample



## HSZ Series

200L drum



Sample (1 kg)



\* Flexible container also available

Minimum order quantity of sample is 1kg.  
Please don't hesitate to contact your local Tosoh sales office.



TOSOH

## **Tosoh Corporation**

Shiba-Koen First Building, 3-8-2, Shiba  
Minato-ku, Tokyo 105-8623, Japan  
Tel : +81 3 5427 5173 Fax : +81 3 5427 5217  
[www.tosoh.co.jp](http://www.tosoh.co.jp)  
E-mail : [zeolite@tosoh.co.jp](mailto:zeolite@tosoh.co.jp)

## **Tosoh USA, Inc.**

3600 Gantz Road, Grove City, OH 43123-1895  
Tel : +1 614 277 4348 Fax : +1 614 875 8066  
[www.tosohusa.com](http://www.tosohusa.com)  
E-mail : [info.tusa@tosoh.com](mailto:info.tusa@tosoh.com)

## **Tosoh Europe B.V.**

Rembrandt Tower, Amstelplein 1  
1096 HA Amsterdam, The Netherlands  
Tel : +31 20 565 0010  
[www.tosoh-europe.com](http://www.tosoh-europe.com)  
E-mail : [info.tse@tosoh.com](mailto:info.tse@tosoh.com)

## **Tosoh Asia Pte. Ltd.**

63 Market Street #10-03 Singapore 048942  
Tel : +65 6226 5106 Fax : +65 6226 5215  
[www.tosohasia.com](http://www.tosohasia.com)  
E-mail : [info@tosoh.com.sg](mailto:info@tosoh.com.sg)

## **Tosoh (Shanghai) Co., Ltd.**

Room 2618, International Trade Center  
No.2201 Yan An West Road, Shanghai  
Tel : +86 21 6270 2810 Fax : +86 21 6270 2820  
[www.tosoh-tsc.com](http://www.tosoh-tsc.com)  
E-mail : [info@tosoh.com.cn](mailto:info@tosoh.com.cn)

ZEOLUM and HSZ are the registered trademarks of Tosoh Corporation in Japan and other countries.

The information provided and recommendations made herein pertain solely to matters of composition of the products based on the test believed to be reliable. The accuracy of this information is not guaranteed. Depending on the measurement methods or instruments, the result may vary from information provided herein. Since the purchaser's actual use of the products is beyond the control of Tosoh Corporation and its related, subsidiary and affiliated companies (collectively, "related companies"), Tosoh Corporation and its related companies are neither responsible nor liable for results obtained from the use of the products. Tosoh Corporation and its related companies make no representations or warranties as to the appropriateness of the products for any use intended or made by the purchaser. Each purchaser must conduct its own testing, safety and regulatory evaluation(s).